



AM 1330 K/10150

Magnet hanger kit

Magnetupphängningssats

Magnetaufhängesatz für Nfz

#	Article #	Order #	Pcs.	EN	SE	DE
1	TC-1029	71349	2	Magnet bracket for frame gauge	Magnetfäste för mätlinjal	Magnethalter für Messlineal
2	AM1227-1 A	10234	1	Magnet bracket for frame, right	Magnetfäste för ram, höger	Magnethalter für Rahmen, rechts
3	AM1227-2 A	10235	1	Magnet bracket f frame, left	Magnetfäste för ram, vänster	Magnethalter für Rahmen, links
4	15439	70693	2	Magnet Bracket	Magnetfäste	Magnethalter

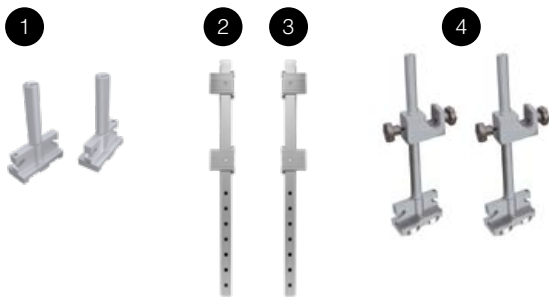

Stabilizers

Gungskydd

Feststelleadapter

#	Article #	Order #	Pcs.	EN	SE	DE
1	JT485	12017	1	Stabilizer	Gungskydd	Feststelleadapter
2	JT119	11903	1	Stabilizer for frame	Gungskydd för ram	Feststelladapter für Rahmen

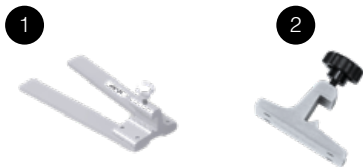

2 pcs of JT485 or JT119 are needed.

2 st JT485 eller JT119 behövs.

2 Stück JT485 oder JT119 sind notwendig.



CA BUS K/72244

Additional kit for buses — JOSAM cam-aligner

Tilläggsats för bussar — JOSAM cam-aligner

Ergänzungssatz für Busse — JOSAM cam-aligner



#	Article #	Order #	Pcs.	EN	SE	DE
1	12278	70473	2	Round bar, L=500 mm	Rundstång, L=500 mm	Rundstange, L=500 mm
2	15439	70693	4	Magnet Bracket	Magnetfäste	Magnethalter
3	15490	70706	4	Vacuum bracket	Sugkopp	Saugteller
4	16456	70844	4	Steel Plate	Stålplatta	Stahlplatte
5	16506	70849	2	Lock	Lås	Schloss
6	CA1026	72026	4	Gauge extension	Mätstång	Mess-Stange

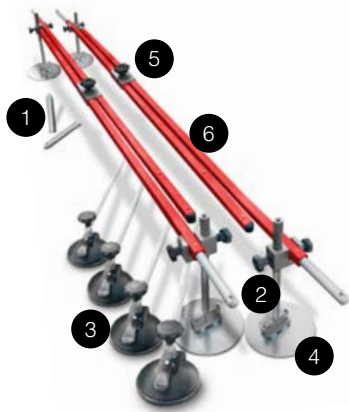

AM BUS K/15877

Additional kit for buses — JOSAM laser AM/truckaligner

Tilläggsats för bussar — JOSAM laser AM/truckaligner

Ergänzungssatz für Busse — JOSAM laser AM/truckaligner



#	Article #	Order #	Pcs.	EN	SE	DE
1	AM1294	10251	2	Joint rail, complete	Skarvskena komplett	Mess-Stangen Verbinder
2	12278	70473	2	Round bar	Rundstång	Rundstange
3	15439	70693	4	Magnet Bracket	Magnetfäste	Magnethalter
4	15490	70706	4	Vacuum bracket	Sugkopp	Saugteller
5	16456	70844	4	Steel Plate	Stålplatta	Stahlplatte





Most buses, coaches and mini buses are built with an integrated body structure design, without a symmetric chassis frame structure. Furthermore, the bodywork of buses and coaches are made of materials like aluminium, plastic and stainless steel. This makes it hard to use magnet adapters. Using the self centering bus adapters solves these problems.

De flesta stadsbussar, långfärdsbussar och minibussar har självbärande karosser. Dessutom förekommer det att karossen är gjord av aluminium, plast eller rostfritt stål, vilket gör det svårt att använda magnetiska upphängare.

Detta kan lösas genom att använda de självcentrerande bussadapterna.

Die meisten Stadt-, Linien- und Minibusse bestehen aus einer Karosseriekonstruktion die nicht wie bei normalen LKW auf einer symmetrischen Rahmenstruktur aufbaut. Der Aufbau besteht häufig aus Aluminium, Plastik oder nichtrostenden Stählen; daher können keine Magnet-Adapter eingesetzt werden. Selbstzentrierende Adapter für Busse lösen diese Probleme.



TC-101-2/70026

Kit with self centering bus adapter

Sats med självcentrerande bussadapter

Selbstzentrierender Adapter für Busse

#	Article #	Order #	Pcs.	EN	SE	DE
1	TC-101	-	2	Self centering bus adapter	Självcentrerande bussadapter	Selbstzentrierender Adapter für Busse

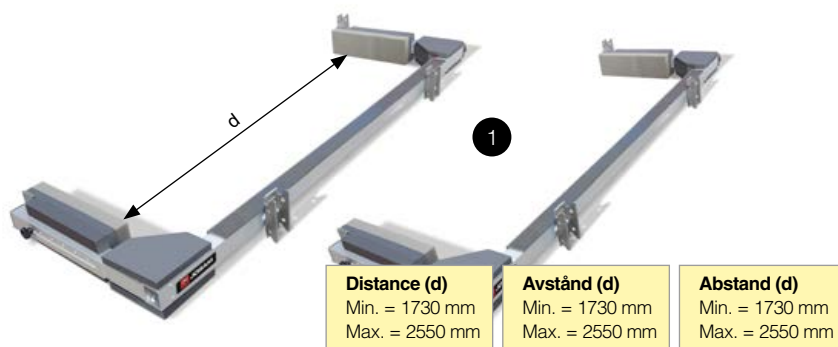

TC-111-2/71646

Kit with self centering minibus adapter

Sats med självcentrerande minibussadapter

Selbstzentrierender Adapter für Minibusse



#	Article #	Order #	Pcs.	EN	SE	DE
1	TC-111	-	2	Self centering minibus adapter	Självcentrerande minibussadapter	Selbstzentrierender Adapter für Minibusse





CA TRAILER K/72104

Additional kit for trailer and semi-trailer

Tilläggsats för släp och semi-trailer

Ergänzungssatz für Anhänger und Auflieger



#	Article #	Order #	Pcs.	EN	SE	DE
1	JT510	12029	1	Adapter for bumper	Adapter för stötfångare	Adapter für Stosstange
2	JT167	11928	1	Bracket for "king-pin"	Fäste för "king-pin"	Halter für "king-pin"
3	AM48 A	10579	1	Adapter for trailer tow bar	Adapter för släpvagnsögla	Adapter für Zuggabel
4	JT485	12017	2	Stabilizer for JT510 + JT167	Gungskydd för JT510 + JT167	Feststelladapter f. JT510 + JT167
5	JT5-8	12046	2	Hanger 870 mm	Upphångningsstång 870 mm	Aufhänge-Stange 870 mm

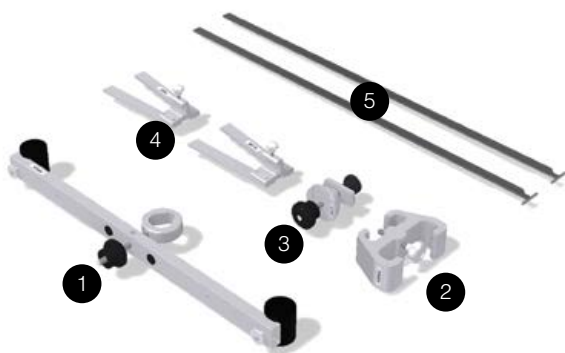

Front adapter extender, 100 mm

Adapterförlängare, 100 mm

Verlängerung für vorderer Adapter, 100 mm

#	Article #	Order #	Pcs.	EN	SE	DE
1	AM1895	21363	1	Front adapter extender	Adapterförlängare	Verlängerung



Fitting adapters / Passande adaptrar / Passende Adapter

AM1622 10360	AM1780 10439	AM1790 10444	AM1854 15167	AM1861 15658	AM1862 15767	AM1891 21202	AM1892 21292
-----------------	-----------------	-----------------	-----------------	-----------------	-----------------	-----------------	-----------------





Front adapters/Adapter fram/Adapter Vorne – Volvo Group

Make/modell/Modell	JT734 15876	AM1622 10360	AM1854 15167	JT733 15875	JT73305 16355	AM1780 10439	AM1862 15767
Volvo FE	(1 pc*)	2 pcs	—	—	—	—	—
Volvo FH (to/till/bis 2011)	—	—	—	—	—	2 pcs	—
Volvo FH (from/från/ab 2012)	—	—	2 pcs	—	—	—	—
Volvo FL	—	—	—	1 pc	(1 pc*)	—	—
Volvo FM (to/till/bis 2011)	—	—	—	—	—	2 pcs	—
Volvo FM (from/från/ab 2012)	—	—	2 pcs	—	—	—	—
Volvo FMX	—	—	2 pcs	—	—	—	—
Renault D narrow	1 pc	2 pcs	—	—	—	—	—
Renault D wide/C	—	—	—	1 pc	1 pc	—	—
Renault K	—	—	—	1 pc	—	—	—
Renault Premium Euro 6	—	—	—	—	—	—	2 pcs
Renault T & T-HIGH	—	—	2 pcs	—	—	—	—

* = Only needed when thread is missing / Används endast när gänga saknas / Wird nur benötigt, wenn Gewinde fehlt

Front adapters/Adapter fram/Adapter Vorne – DAF, Iveco, MAN, Mercedes, Scania, Ford

Make/modell/Modell	AM1790 10444	AM1861 15658	AM1622 10360	AM1879 16383	JT510 12029	AM1891 21202	AM1892 21292
DAF CF/XF (till/to/bis 2012)	2 pcs	—	—	—	—	—	—
DAF CF/XF Euro 6 (from/från/ab 2012)	—	2 pcs	—	—	—	—	—
Iveco Stralis	—	—	(2 pcs*)	—	—	—	—
Iveco Trakker	—	—	—	—	1 pc	—	—
Iveco S-Way	—	—	—	—	—	—	2 pcs
MAN TGA	—	—	2 pcs	—	—	—	—
MB Antos & Actros (from/från/ab 2011)	—	—	(2 pcs*)	—	1 pc	—	—
Scania 4/5/6	—	—	—	2 pcs	—	—	—
Ford F-max	—	—	—	—	—	1 pc	1 pc
Ford Cargo 4142	—	—	—	—	—	—	2 pcs
Ford Cargo 1833/1842	—	—	—	—	—	1 pc	1 pc

* = Not guaranteed to fit all models / Kan inte garanteras passa till alla modeller / Es kann nicht garantiert werden, dass alle Modelle passen



Adapter front, Volvo FH/FM (to 2011)
Adapter fram, Volvo FH/FM (till 2011)
Adapter Vorne, Volvo FH/FM (bis 2011)

#	Article #	Order #	Pcs.	EN	SE	DE
1	AM1780	10439	1	Adapter Volvo FH/FM (to 2011)	Adapter Volvo FH/FM (till 2011)	Adapter Volvo FH/FM (bis 2011)



2 pcs of AM1780 are needed.

2 st AM1780 behövs.

2 Stück AM1780 sind notwendig.

Adapter front, Volvo FH/FM (from 2012) & FMX, Renault T & T-High
Adapter fram, Volvo FH/FM (från 2012) & FMX, Renault T & T-High
Adapter Vorne, Volvo FH/FM (ab 2012) & FMX, Renault T & T-High

#	Article #	Order #	Pcs.	EN	SE	DE
1	AM1854	15167	1	Adapter Volvo FH/FM (from 2012) & FMX, Renault T & T-High	Adapter Volvo FH/FM (från 2012) & FMX, Renault T & T-High	Adapter Volvo FH/FM (ab 2012) & FMX, Renault T & T-High



2 pcs of AM1854 are needed.

2 st AM1854 behövs.

2 Stück AM1854 sind notwendig.



Adapter front, Volvo FL, Renault D wide/C/K Adapter fram, Volvo FL, Renault D bred/C/K Adapter Vorne, Volvo FL, Renault D breit/C/K

#	Article #	Order #	Pcs.	EN	SE	DE
1	JT733	15875	1	Adapter Volvo FL, Renault D wide, C and K	Adapter Volvo FL, Renault D bred, C och K	Adapter Volvo FL, Renault D breit, C und K

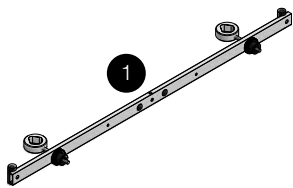

In some cases, one piece of JT73305 needs to be attached to one side. See page 8 and picture above right.

I vissa fall behöver även en st JT73305 fästas på ena sidan. Se sidan 8 samt bild ovan till höger.

In einigen Fällen muss ein Stück JT73305 an einer Seite befestigt werden. Siehe Seite 8 und Bild oben rechts.

Adapter front, Volvo FE, Renault D narrow Adapter fram, Volvo FE, Renault D smal Adapter Vorne, Volvo FE, Renault D schmal

#	Article #	Order #	Pcs.	EN	SE	DE
1	JT734	15876	1	Adapter Volvo FE, Renault D narrow	Adapter Volvo FE, Renault D smal	Adapter Volvo FE, Renault D schmal

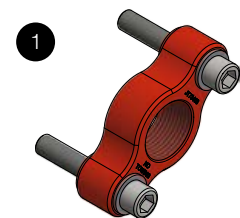

To be used together with 2 pcs of AM1622 when threaded mount plate not present.

Används tillsammans med 2 st AM1622 när gängad monteringsplatta saknas.

Wird mit 2 Stück AM1622 verwendet, wenn die Montageplatte mit Gewinde fehlt.



Adapter plate, Volvo FL, Renault D wide/C Adapterplatta, Volvo FL, Renault D bred/C Adapterplatte, Volvo FL, Renault D breit/C

#	Article #	Order #	Pcs.	EN	SE	DE
1	JT73305	16355	1	Adapter plate Volvo FL, Renault D wide/C	Adapterplatta Volvo FL, Renault D bred/C	Adapterplatte Volvo FL, Renault D breit/C



To be used together with 1 pc of JT733 if sprint mount not present on one side.

Används tillsammans med 1 st JT733 om sprintfäste saknas på en sida.

Wird mit 1 Stück JT733 verwendet, wenn die Sprint-Halterung auf einer Seite fehlt.

Adapter front, Renault Premium Euro 6 Adapter fram, Renault Premium Euro 6 Adapter Vorne, Renault Premium Euro 6

#	Article #	Order #	Pcs.	EN	SE	DE
1	AM1862	15767	1	Adapter Renault Premium Euro 6	Adapter Renault Premium Euro 6	Adapter Renault Premium Euro 6



2 pcs of AM1862 are needed.

2 st AM1862 behövs.

2 Stück AM1862 sind notwendig.



Adapter front, DAF CF/XF (Gen. 2 - Euro 6 ≥2012)
Adapter fram, DAF CF/XF (Gen. 2 - Euro 6 ≥2012)
Adapter Vorne, DAF CF/XF (Gen. 2 - Euro 6 ≥2012)

#	Article #	Order #	Pcs.	EN	SE	DE
1	AM1861	15658	1	Adapter DAF CF/XF (Gen. 2 - Euro 6 from 2012)	Adapter DAF CF/XF (Gen. 2 - Euro 6 från 2012)	Adapter DAF CF/XF (Gen. 2 - Euro 6 ab 2012)



2 pcs of AM1861 are needed.

2 st AM1861 behövs.

2 Stück AM1861 sind notwendig.

Adapter front, DAF CF/XF (Gen. 1 ≤2012)
Adapter fram, DAF CF/XF (Gen. 1 ≤2012)
Adapter Vorne, DAF CF/XF (Gen. 1 ≤2012)

#	Article #	Order #	Pcs.	EN	SE	DE
1	AM1790	10444	1	Adapter DAF CF/XF (Gen. 1 to 2012)	Adapter DAF CF/XF (Gen. 1 till 2012)	Adapter DAF CF/XF (Gen. 1 bis 2012)

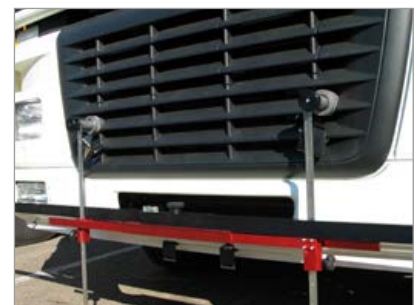

2 pcs of AM1790 are needed.

2 st AM1790 behövs.

2 Stück AM1790 sind notwendig.



Adapter front, Scania series 4/5/6

Adapter fram, Scania serie 4/5/6

Adapter Vorne, Scania Serie 4/5/6

#	Article #	Order #	Pcs.	EN	SE	DE
1	AM1879	16383	1	Adapter Scania series 4/5/6	Adapter Scania serie 4/5/6	Halterung Scania Serie 4/5/6

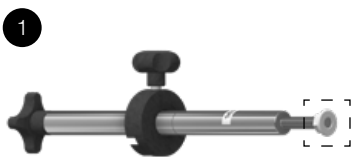

Scania series/serie/Serie 4/5



Scania series/serie/ Serie 6

Flange nut only needed for series 4/5.

Flänsmutter används bara till serie 4/5.

Flanschmutter nur für Serie 4/5 erforderlich.

2 pcs of AM1879 are needed.

2 st AM1879 behövs.

2 Stück AM1879 sind notwendig.

Adapter front, Iveco Trakker, Mercedes-Benz Antos & Actros (from 2011)

Adapter fram, Iveco Trakker, Mercedes-Benz Antos & Actros (från 2011)

Adapter Vorne, Iveco Trakker, Mercedes-Benz Antos & Actros (ab 2011)

#	Article #	Order #	Pcs.	EN	SE	DE
1	JT510	12029	1	Adapter Iveco Trakker, MB Antos & Actros (from 2011)	Adapter Iveco Trakker, MB Antos & Actros (från 2011)	Adapter Iveco Trakker, MB Antos & Actros (ab 2011)



JT510 is included in trailer kits and some wheel alignment kits.

JT510 ingår i tilläggsatser för släpvagnar och i vissa hjulmätssatser.

JT510 ist in Anhänger-Sätze und einigen Achsvermessungs-Sätze enthalten.



Adapter front MAN TGA, Renault D narrow, Iveco Stralis, MB Actros (≥2011) & Antos, Volvo FE
Adapter fram MAN TGA, Renault D smal, Iveco Stralis, MB Actros (≥2011) & Antos, Volvo FE
Adapter Vorne MAN TGA, Renault D schmal, Iveco Stralis, MB Actros (≥2011) & Antos, Volvo FE

#	Article #	Order #	Pcs.	EN	SE	DE
1	AM1622	10360	1	Adapter MAN TGA, Renault D narrow, Iveco Stralis, MB Actros (from 2011) & Antos, Volvo FE	Adapter MAN TGA, Renault D smal, Iveco Stralis, MB Actros (från 2011) & Antos, Volvo FE	Adapter MAN TGA, Renault D schmal, Iveco Stralis, MB Actros (ab 2011) & Antos, Volvo FE

1



2 pcs of AM1622 are needed.

2 st AM1622 behövs.

2 Stück AM1622 sind notwendig.

Adapter front, Ford F-Max & Cargo, Iveco S-way
Adapter fram, Ford F-Max & Cargo, Iveco S-way
Adapter Vorne, Ford F-Max & Cargo, Iveco S-way

#	Article #	Order #	Pcs.	EN	SE	DE
1	AM1891	21202	1	Adapter Ford F-Max (left), Ford Cargo 1833/1842 (left)	Adapter Ford F-Max (vänster), Ford Cargo 1833/1842 (vänster)	Adapter Ford F-Max (links), Ford Cargo 1833/1842 (links)
2	AM1892	21292	1	Adapter Ford F-Max (right), Ford Cargo 1833/1842 (right), Ford Cargo 4142, Iveco S-way	Adapter Ford F-Max (höger), Ford Cargo 1833/1842 (höger), Ford Cargo 4142, Iveco S-way	Adapter Ford F-Max (rechts), Ford Cargo 1833/1842 (rechts), Ford Cargo 4142, Iveco S-way

1



2



See table on page 5.

Se tabell på sida 5.

Siehe Tabelle auf Seite 5.