



JOSAM ADAS alignment

Calibration equipment for active safety sensors





Avoiding rear-end collisions with active safety sensors

To reduce and mitigate rear-end collisions, OEM's and truck manufacturers have developed active safety sensors which provide an advanced system for collision warning and emergency braking. By warning the driver of imminent obstacles or by providing automatic braking assistance, a significant number of accidents can be avoided.

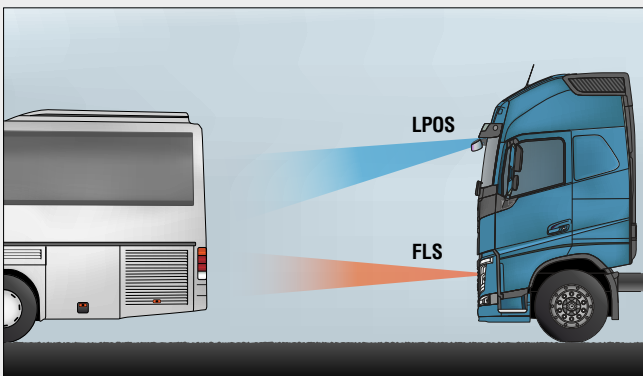

Basic functionality

The system is based on two sensors. A radar sensor (FLS) measures the distance to and speed of the vehicle ahead, and a camera (LPOS) identifies what kind of vehicle it is.

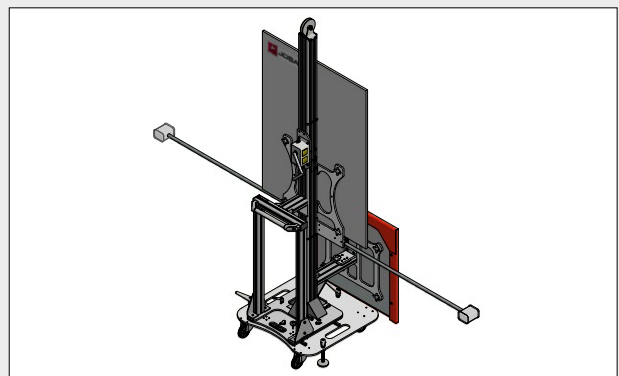

Sensor calibration

The JOSAM calibration equipment is used together with the Cam-aligner wheel alignment system and is capable of calibrating both the LPOS and FLS sensors.

Representative:

Manufacturer:

CAR-O-LINER®  **JOSAM®**

Car-O-Liner Group AB • Box 419 • SE-701 48 Örebro • Sweden
Tel: +46 19 30 40 00 • Fax: +46 19 32 03 16
E-mail: info@josam.se • Internet: www.josam.se